



Acousto-Optical Q-switch

The acousto-optical Q-switch often used in the laser marking makes use of mutual interaction between an ultrasonic wave and a light beam in a scattering medium. The light beam that enters in a direction forming a Bragg angle to the wave surface of the acoustic wave in the scattering medium is diffracted in accordance with periodic changes in the diffraction rate produced by the acoustic wave.

The situation is briefly explained in Figure 1. First of all, an RF signal is impressed to the transducer adhered to the molten quartz and thickness extensional vibration is produced. Ultrasonic shear waves are caused to advance in the molten quartz by this vibration, and phase grating formed by acoustic waves is produced. The laser beam is diffracted when it satisfies the Bragg angle with respect to this phase grating, and is separated in space from the incident light.

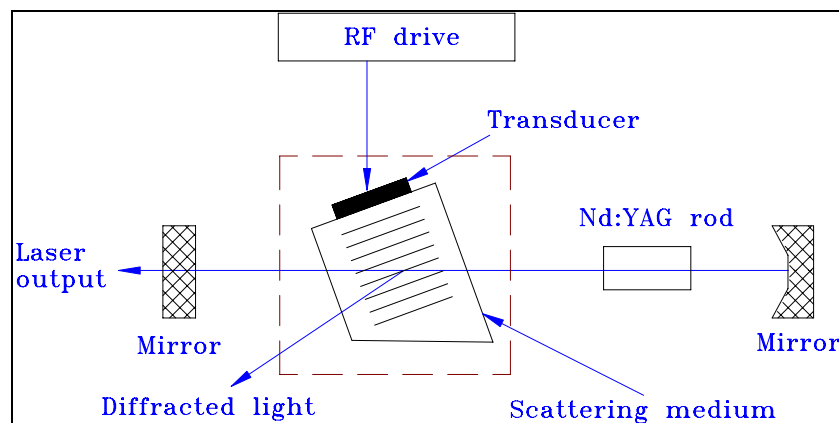

Figure 1: Principle of A-O Q-switch

If the laser optical resonator is constructed against 0-dimensional diffracted light (undiffracted light), the diffracted light deviates from the laser optical resonator axis when a RF signal is impressed. As a result, loss occurs in the laser optical resonator and laser oscillation is suppressed. To make use of this phenomenon, an RF signal is impressed for a certain length of time only (status of low Q-value) to suspend laser oscillation. In the meantime, the population inversion of the Nd:YAG rod is accumulated by continuous pumping. When the RF signal is reduced to zero (status of high Q-value) and the loss to the laser optical resonator is removed, the accumulated energy is activated as laser oscillation in a pulse form within an extremely short length of time. They are Q-switch pulses.

This situation is briefly explained in Figure 2. When an RF signal is subjected to pulse modulation, it is possible to periodically take out a Q-switch pulse. When the period of Q-switch pulses becomes shorter than the life (about 200 μ s) of the higher order of the Nd:YAG rod, however, the population inversion decreases and the peak value of Q-switch pulses decreases.

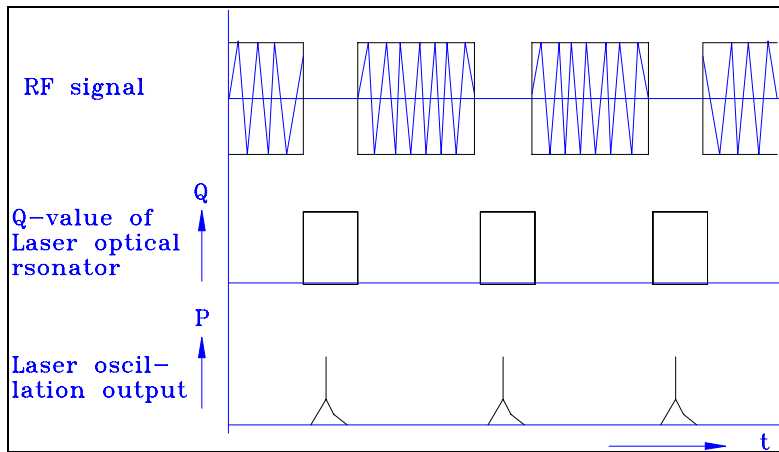

Figure 2: Laser oscillation output of a Q-switch laser

1. QS Series Q-switch Element

A water-cooled acousto-optic Q-Switch for use in high-power Nd:YAG laser systems. Combining top grade fused silica with high quality optical finishing and in-house anti-reflection coatings, this Q-Switch exhibits very low insertion loss and high damage threshold. Through an innovative design and manufacturing process, RF powers up to 100W may be applied.

Standard options include a choice of frequencies (24 to 68MHz), active apertures (1 to 8mm), acoustic modes (compressional for linear polarisation, shear for unpolarised) and water connectors. Customised housings are available for OEM's.

Specifications

Model No:	See "Options" below
Interaction Medium:	Fused Silica
Operational Wavelength:	1064nm
Anti Reflection Coating:	Hard multi-layer dielectric
- Reflectivity:	$\leq 0.2\%$ / surface ($< 0.1\%$ typical)
- Damage Threshold:	$> 500\text{MW cm}^{-2}$
Insertion Loss:	$\leq 10\%$ ($< 5\%$ typical)
Active Aperture:	See "Options" below
VSWR:	$\leq 1.2:1$
Maximum CW Drive Power:	100W
Thermal Interlock:	+50°C



Water Cooling

Flow rate:	190cc / min (minimum)
Water Temperature:	
- Recommended operating:	32°C
- Recommended maximum:	40°C
Water Connectors:	See "Options" below

Options

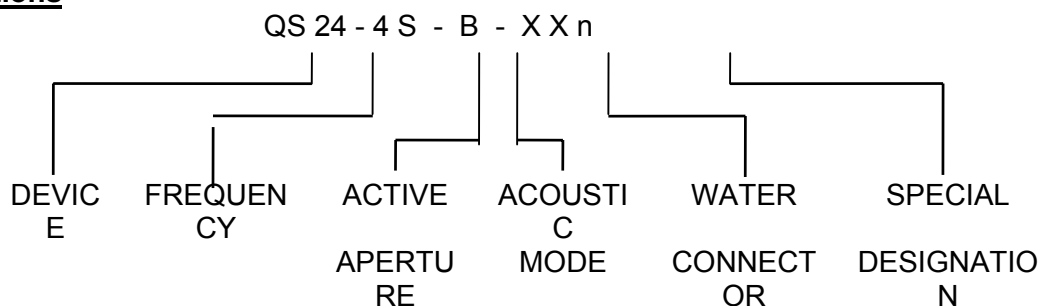

Device:	QS	- Q-Switch
Frequency:	24, 27	- Value in MHz
Aperture:	3, 4, 5, 6-5, 8	- Value in mm (In general, the aperture of Q-switch is equal to or larger than the diameter of laser beam or YAG rod.)
Acoustic Mode:	C	- Compressional
	S	- Shear
Water Connector:	S	- Screw-on (Swagelok etc.)
	B	- Barbed Push-on
Special Designation:		- For non-standard Q-switch models identification characters which define the configuration may be allocated.

AO Q-Switch at 1319-1342nm Wavelength

Model No.	QS027-4H-xxx
Interaction material	Infrasil (water-free fused silica)
Wavelength	1319-1342nm
AR coating reflectivity	< 0.2% per surface
Damage threshold	> 100MWcm ⁻²
Polarisation	Linear (vertical to base)
Interaction length	46.0mm
RF frequency	27.12MHz
VSWR	< 1.2 1 at 50.
Acoustic Mode	Compressional
Active aperture	5.0mm
Loss modulation	> 80% at 50W RF power
Housing	Standard QS24/27 range (Aluminium)
Water connectors	Barbed

2. Super Q-Switch

QS2x-xD-x-xxx

- High efficiency
- For unpolarised, high power, high gain lasers
- 2 x 50W RF power handling

A new compressional mode, water-cooled, AO Q-Switch designed for use in high power unpolarised lasers giving faster switching, better pulse-to-pulse stability and higher power densities. Enhance your systems performance with greater punch and increased power, specifically for laser processing applications.



Before the Super Q-Switch, some customers were using 2 x Compressional mode Q-Switches (like the QS27-4C-S) in the same cavity. One of the Q-Switches is rotated 90degrees to the other. Because the Compressional mode Q-Switch is more efficient for polarised light, the first Q-Switch would block one polarisation & the second Q-Switch blocks the other. This is a good solution, but takes a large space in the cavity. The Super Q-Switch gives the same performance as using 2 x Compressional Q-Switch, but they are incorporated into 1 device.

This Q-switch uses a dual channel driver to operate two orthogonal compressional mode transducers bonded to a single monolithic optical cell and mounted in one convenient housing. Our proprietary bonding techniques and power handling technology allows this device to operate up to 50W per channel giving an efficient, compact, single device for the next generation of high power, high gain, solid state lasers.

Interaction Material	Fused Silica
Wavelength	1047 to 1064nm
Anti-Reflection Coating	< 0.2% per surface
Damage Threshold	> 500MWcm ⁻² (1GWcm ⁻² typical)

Transmission (single pass)	> 99.6%
Frequency	24.00 or 27.12MHz
VSWR	< 1.2:1 (50. input impedance)
Active Aperture	1.6, 2, 3, 4, 5 or 6.5mm ²
Clear Aperture	9 x 9mm
Acoustic Mode	Compressional (Orthogonal)
Rise-Time / Fall-Time	109ns/mm
RF Power Rating	2 x 50W cw
Water Flow Rate	190cc / minute, minimum
Maximum Water Temperature	+40°C (recommended, 22°C to 32°C)
Water Connectors	Screw-fit or Barbed (push-on)
Thermal Switch Cut-Off	+55°C ± 5°C
Housing / Flow Chamber Material	Aluminium HE30TF

Driver Selection

- Aperture size 1.6D, 2D or 3D, use 25W dual channel driver
- Aperture size 4D, 5D or 6.5D, use 50W dual channel driver

3. Q-Switch used in DPSS lasers

3.1 QS041-10G-GH12

- DPSS Nd:YAG / Nd:YVO₄, linearly polarized
- Compact conduction cooled, crystal quartz
- 2mm active aperture



A compact, conduction-cooled, acousto-optic Q-Switch for use lasers. Utilising the same manufacturing technology as our industry standard, high power QS24/27 series, these compact devices offer unrivalled reliability through superior optical quality and coatings. 4

Optimised for use with linearly polarised beams of up to 1.6mm diameter, offering loss modulation figures exceeding 85%. Utilising Crystal Quartz as the interaction material to give increased efficiency and high thermal transfer properties allowing use at RF powers of up to 15W, conduction-cooled.

This Q-Switch can also be customised to feature alternative frequencies, active apertures and housing designs, our team of scientists will be pleased to discuss variations with you.

Interaction Material	Crystal Quartz
Wavelength	1047 to 1064nm
Polarisation	Linear, vertical to base
Anti-Reflection Coating	< 0.2% per surface
Damage Threshold	> 1GWcm ⁻²
Transmission (single pass)	> 99.6%
Frequency	40.68MHz
VSWR	< 1.2:1 (50Ω input impedance)
Active Aperture	2.0mm
Clear Aperture	3.0mm
Acoustic Mode	Compressional
Rise-Time / Fall-Time	109ns/mm
Loss Modulation	> 85% at 15W
Beam Separation	7.3mrad
Acceptance Angle (full)	6.1mrad
RF Power Rating	15W cw
Cooling	Conduction through base
Q-switch driver	N38041-15DMA05 OR N39041-15DMFPS

3.2 Water-cooled Q-switch QS041-4G-HL2

Model No	QS041-4G-HL2
Device	AO Q-Switch
Interaction material	Fused Silica
Wavelength	1047 to 1064nm
Damage threshold	> 500MW/cm ²
AR coating reflectivity	< 0.2% per surface
Transmission	> 99.6%
Frequency	40.68MHz
Optical polarisation	Linear, vertical to base
Active aperture	2.0mm
Acoustic mode	Compressional
Rise-time (10-90%)	109ns/mm
Diffraction efficiency	≥ 85%
RF Power	25W (Max)
Housing material	Corrosion resistant aluminium (Sureflow)
Housing dimensions	Refer to drawing
Q-switch driver	N39041-24DMFPS

AO Q-switch Driver (RF Driver)

1. QSD Series Q-switch Driver

A high power RF driver module is available in output powers of 50W, 75W or 100W. Powered from 220VAC or 110VAC, the modulation inputs allow either full digital control or activation of an internal pulse generator. First pulse suppression is automatically implemented.

Main Specifications:

RF power output: 50W, 75W or 100W
Frequency: 27.125MHz
VSWR: ≤1.2:1
Modulation repetition rate: 800Hz-50KHz
First pulse suppression
Modulation control inputs: digital TTL
Driver over-heat, Q-Switch over-heat
Internal over-temperature protection and over-current protection
Digital display of frequency
Supply voltage input: 220VAC/110VAC, <150W



Model Numbers:

QSD-2750 (50W), QSD-2775 (75W) or QSD-27100 (100W)

Dimension:

19" 2U frame, 483×88×200mm

2. N390 Series Q-switch Drivers (RF Driver)

N390xx-yyDMzzz

A compact high power RF driver module is available in output powers of 50 or 100W. Powered from 28VDC, the modulation inputs allow either full digital control or activation of an internal pulse generator. First pulse suppression is implemented through either analogue modulation, RF off analogue control, triggered first pulse suppression, or triggered pre-pulse kill, as described in our FPS guidance notes. On board LED's and TTL logic outputs monitor driver status and cooling is through forced air over the heat sink.



Specification

RF Power Output (yy)	50 or 100W
Frequency (xx=24, 27, 41)	24.00MHz, 27.12MHz or 40.68MHz (50W)
First Pulse Suppression (zzz=FPS, PPK, R05, A05, A13)	Triggered First Pulse Suppression: FPS Triggered Pre-Pulse Kill: PPK RF Off Analogue Control: 0-5V R05 Analogue Modulation: 0-5V A05 / 2-13V A13
Frequency Tolerance	± 0.02%
Output Impedance	50Ω
RF Fall-Time	< 100ns (60ns typical)
RF Rise-Time	250ns typical
Extinction Ratio	> 52dB
Harmonic Levels	< -30dB at full power
Supply Voltage Input	28VDC ±5%
Supply Current Input	6.5A (50W), 9.0A (100W)
Modulation Control Inputs	Digital TTL (TTL high = RF off)
Modulation Repetition Rate	100Hz to 100kHz
Internal Pulse Width	1μs to 14μs, typical
Status Monitoring	Power supply on, High VSWR RF power low, RF power maximum Driver over-heat, Q-Switch over-heat
Housing	Module
Storage Temperature	-20°C to +85°C
Operating Temperature	+10°C to +55°C

1. All dimensions can be found from our websites.
2. EO Q-switches available upon request.

Frequently Asked Questions

Which parameters do I need to specify if I want to order a Q-Switch?

You will need to specify the frequency, aperture, acoustic mode and the type of water connector.

Which frequency should I use?

The answer depends on your location. There are various regulatory bodies (for example the ITU) that stipulate the maximum levels of RF radiation that can be emitted in certain frequency bands. The Q-Switch drive frequency is usually chosen to be within one of the permitted bands for the country in which it will operate. Historically, 24.0MHz has been the chosen frequency in the USA and Japan and 27.12MHz in Europe and elsewhere. However, this has been less rigidly observed in recent years and 27.12MHz is now used widely in the USA.

What is the difference between clear aperture and active aperture? ,

The clear aperture of a Q-Switch is defined by the size of the block of silica in which the light and sound interact. For the QS24/27 Series the minimum clear aperture is 9mm. The active aperture is defined by the height of the acoustic beam inside the silica block. This is the dimension that matters when specifying a Q-Switch.

How do I select the appropriate aperture for my application?

As a rule of thumb, the active aperture of the Q-Switch should be the same as the beam diameter of the laser at the point where the Q-Switch will be located. If the gain of the laser is modest it may be possible to use a Q-Switch with an active aperture one size smaller than the actual beam diameter (e.g. a 3mm active aperture Q-Switch in a laser with a 4mm diameter rod). This has the advantage of requiring lower RF drive power (drive power scales linearly with active aperture), which means less heat input and consequently greater efficiency and improved beam quality. It may even mean a lower cost driver can be used. On the downside, alignment of the Q-Switch in the cavity may be more critical.

Which acoustic mode would suit me best?

The choice is between shear (S) mode and compressional (C) mode (also known as longitudinal mode). If your laser is unpolarised you should choose shear mode. For polarised systems better results (less RF power = lower cost driver, less heat = better beam quality) will be obtained by using a compressional mode Q-Switch.

Which water connector should I choose?

The choice is between screw-on (S) connectors with a nut and olives which grip the outside of the flexible tubing, and barbed (B) push-on connectors, which grip the inside of the flexible tubing. There is little to choose between the two and it usually depends what type of pipe fitting is used as standard in the laser system. Overall the push-on fittings are probably best because there is no danger of them restricting the water flow. (The olives in the screw-on type can constrict the soft-wall tubing usually used in laser systems.)

How do I know that the Q-Switch is not over-heating?

The Q-Switch is fitted with a thermal interlock. If, for example, the cooling water fails it will shut down the driver when the temperature reaches 50 degrees C, preventing damage to the Q-Switch.

What is the optimum operating temperature of the Q-Switch?

The temperature should be set slightly above ambient to prevent the possibility of condensation forming on the optical surfaces of the Q-Switch. Around 32 degrees C is typical. For optimum performance and lifetime we do not recommend operating the Q-Switch at temperatures above 40 degrees C.

How do I select the appropriate RF driver for my application?

[See Q-switch drivers FAQ.](#)

How do I know that the QS24/27 Series Q-Switch is the best choice for my application?

Please call one of our engineers if you are in any doubt about which Q-Switch to use. The QS24/27 Series Q-Switches are 'industry standard' devices that have been developed and refined over many years. As a result they are very reliable and because they are manufactured in large quantities they are lower cost than some of the more specialised products we can offer. Basically, if you have a lamp-pumped industrial or medical Nd:YAG laser this is probably the Q-Switch for you. It is also suitable for the latest generation of high-power industrial diode-pumped lasers.

I am designing a compact laser and the QS24/27 Series Q-Switch is too large. What should I do?

G&H manufacture a range of standard compact Q-Switches that may be suitable for your application. If not, we have considerable experience of designing application-specific Q-Switches. We supply Q-switches to many of the leading diode-pumped laser manufacturers and it is likely that we will have a design that can easily be adapted to suit your requirements.

I have a single-mode polarised laser. Will the QS24/27 Series Q-Switch be suitable? ,

Yes. You can use a compressional mode version with a small active aperture (3mm or less). However, you may find that the integrated Q-switch, with its integral RF driver is a more cost effective solution that also offers performance advantages in terms of higher average Q-Switched output power.

How much laser power can I hold off? ,

It depends on the design of your laser cavity, where the Q-Switch is placed in it and so on. Hold-off is not a parameter of the Q-Switch alone, but of the Q-Switch/laser combination. We can however determine the extra-cavity loss modulation of the Q-Switch, which is a direct measure of its effectiveness at blocking the laser beam.

I have a high gain laser and need the maximum possible loss modulation. How do I achieve this? ,

There are two ways; by using two compressional mode Q-Switches in series and orientated such that the acoustic beams are orthogonal to each other you can obtain a high, polarisation insensitive, loss modulation with minimum RF drive power. Also available is a newly developed Q-Switch incorporating two orthogonal compressional mode transducers in a single monolithic cell and mounted in one convenient housing. A dual channel RF driver is available for both applications.

Can I trust the damage threshold quoted in the data sheet?

Yes. We periodically send a sample Q-Switch to a NIST certified test house to have the optical damage threshold verified. G&H take the utmost care in the polishing of the optical surfaces and in their preparation and coating. All these operations are carried out in-house in order to have total control of the process.

Pockels Cells & Pockels Cell Drivers (EO Q-switches)

A Pockels cell alters the polarization state of light passing through it when an applied voltage induces birefringence changes in an electro-optic crystal such as KD*P and BBO. When used in conjunction with polarizers, these cells can function as optical switches, or laser Q-switches. Frequently, Q-switches are employed in laser cavities for the purpose of shortening the output pulse, resulting in a light beam with enhanced peak intensity. In order to provide the device best suited to your purpose, we offer the industry standard QX series, economical IMPACT cells, BBO-based LightGate, and large-aperture TX Pockels cell lines. High-speed electronic drivers properly matched to the cell produce the best results for short pulse applications.

From the world leader in nonlinear materials and electro-optic devices comes the ideal Pockels cell for OEM applications, the IMPACT. Once again, we set the industry standard - and at an exceptional price.

The IMPACT employs the finest strain-free, highly deuterated KD*P available. Ceramic apertures ensure robust performance in demanding applications. Ultra-high-damage threshold Sol Gel and dielectric AR coatings are offered for a variety of laser wavelengths. The standard pin-type connectors (superior for high-voltage applications) provide quick connections and simplified design and assembly. Conventional threaded connectors are available as an option.



Applications:

- OEM laser systems
- Medical/cosmetic lasers
- Versatile R&D laser platforms
- Military & aerospace laser systems

FEATURES	BENEFITS
CCI Quality - economically priced	Exceptional value
Finest strain-free KD*P	High contrast ratio High damage threshold Low 1/2 wave voltage
Space efficient	Ideal for compact lasers
Ceramic apertures	Clean and highly damage-resistant
High contrast ratio	Exceptional hold-off
Quick electrical connectors	Efficient/reliable installation
<i>Ultra-flat</i> crystals	Excellent beam propagation

Typical Specification

Electro-optical @ 1064nm			
1/4 Wave Voltage: 3.3 kV			
Transmitted Wave Front Error : <1/8 Wave			
ICR>2000:1			
VCR>1500:1			
Capacitance: 6 pF			
Sol Gel Damage Threshold @ 1064nm, 10ns pulse: 40J/cm ²			
Housing Dimensions	IMPACT 8	IMPACT 10	IMPACT 13
Aperture	8 mm	10 mm	13 mm
Length	25 mm	39 mm	45 mm
Diameter	19 mm	25.35 mm	25.35 mm

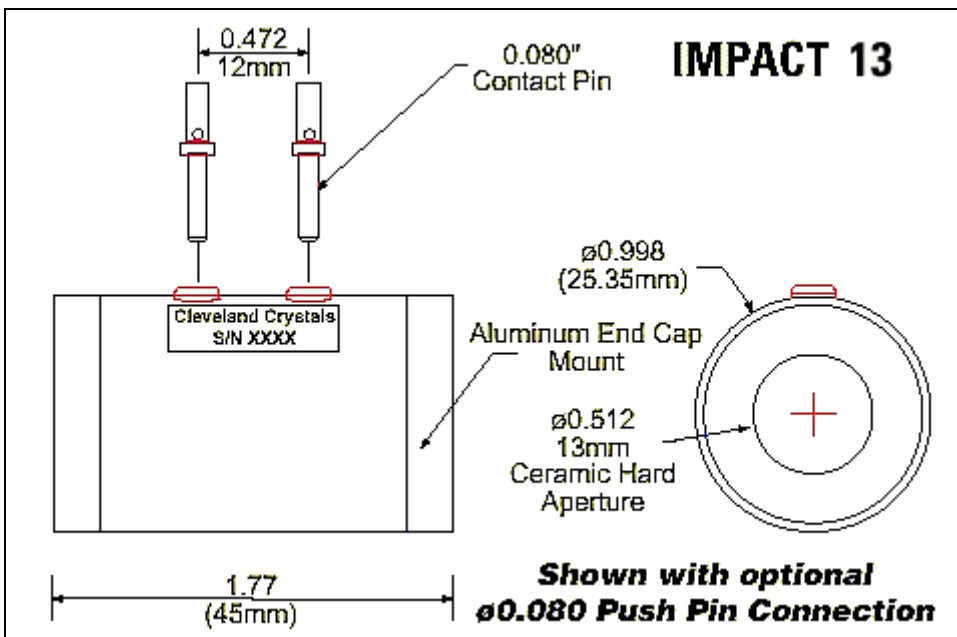
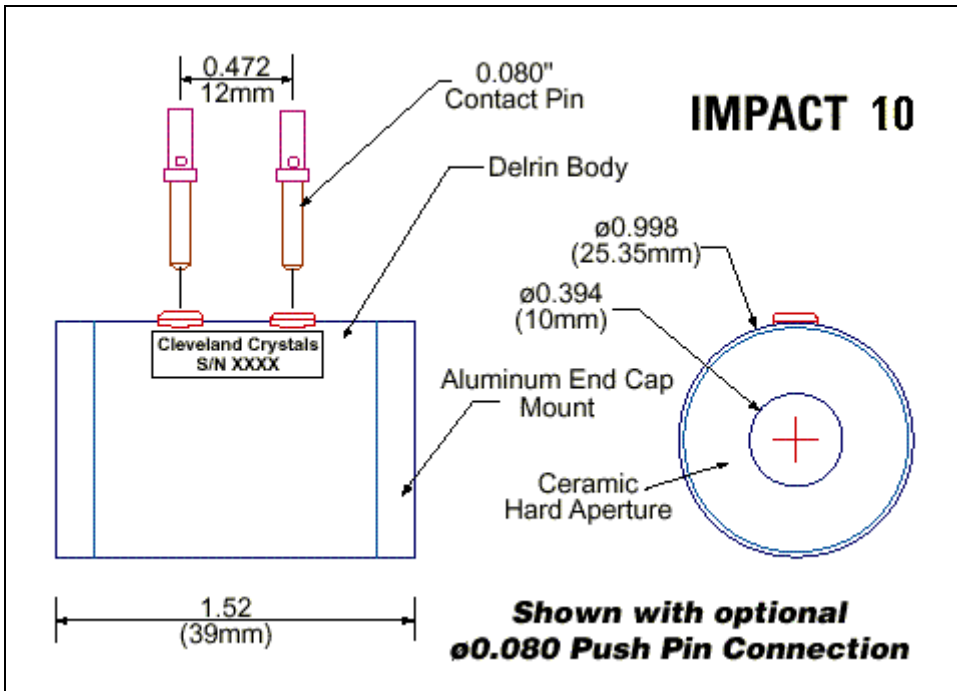
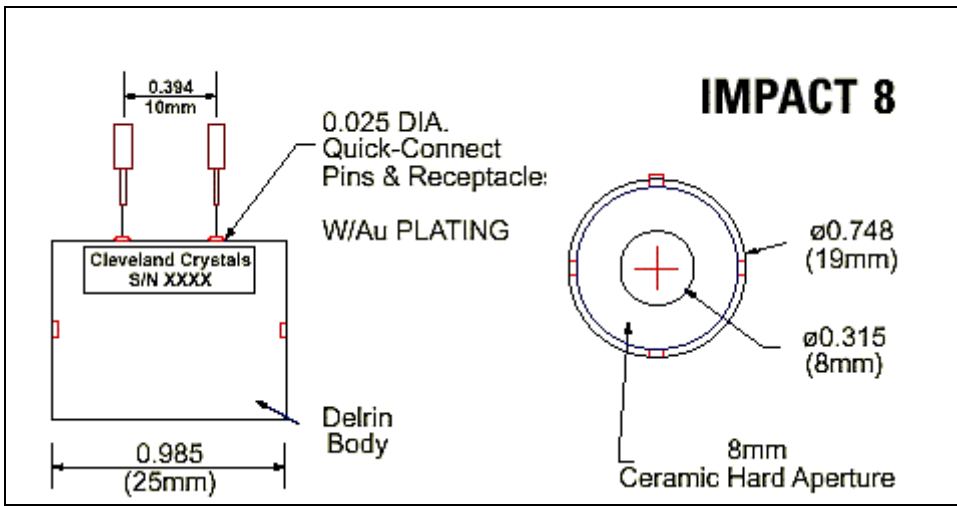

Q-switch Driver

Frequency: 400Hz
Pulse width: 30ns
Output voltage: 5000V
Input voltage: 15VDC