

STCW Laser Power Supply

Operation Manual



Sintec Optronics Pte Ltd

196 Pandan Loop #07-26

Pantech Industrial Complex Singapore 128384

Tel: +65 67781866 Fax: +65 67781781

E-mail: sales@SintecOptronics.com or
sales@sintecoptronics.com.sg

URL: <http://www.SintecOptronics.com> or
<http://www.SintecOptronics.com.sg>

Contents

Chapter 1	Introduction
Chapter 2	Explanation of Model Number
Chapter 3	Main Technical Specifications
Chapter 4	Installation
Chapter 5	Operation Instruction
Chapter 6	Attentions
Chapter 7	Troubleshooting Guide
Chapter 8	Accessories
Chapter 9	Definition of External Control Interface

Company Profile of Sintec Optronics Pte Ltd

**Important: Please read this operation manual carefully
before using the laser power supply!**

Chapter 1 Introduction

The STCW series laser power supplies are made for CW lamp-pumped Nd:YAG lasers. The main circuit of the power supply is based on power electronic module IGBT, adopts PWM technique to yield conversion efficiency more than 90%, and outputs constant current with high accuracy and low current ripple. Ignition circuits which produce a high voltage pulse consists of three steps: series high voltage unit for igniting the lamp, LC unit to relay the power, and low –voltage-constant-current to continue the lamp current. Automatic igniting is achieved with igniting-detecting circuit. The successful ratio of one-time ignition is more than 99%. The high voltage rises smoothly, and its magnitude can be adjusted to meet the dispersible characteristics of the krypton lamps, and to reduce the spattering of the electrode material at the same time, and further to reduce the damage to the krypton lamp caused by high voltage triggering.

The soft-charging circuit and soft-starting circuit are provided to avoid the voltage spiking and in-rush current in the event of starting. Display shows the set current and operation current at different time. The function of “work/sleep” is designed to output normal current at working and low holding current at the time of stand by, so as to increase the efficiency of the power supply, lighten the heat exchanger system, and prolong the lifetime of the lamp as well. Conveniently turns switch to Run/Stop status, adjust output current, and show the working status through the inner/outer control selection.

Excellent design makes the power supply maintained easily and perfect design of circuit protects the device from over voltage, over current and over heat.

There are the following advantages of our products:

- High reliability
- Advanced design of the whole circuits system highly improves the electrical characteristics of the power supply.
- Anti-dust design
- Anti-vibration design
- Easy maintenance
- Malfunction indicators
- Strict testing and 48hour full-load testing in the factory
- Temperature test in -10°C~70°C to ensure that it works stably in the ambient temperature at 0°C~50°C.

- Test in relative humidity 90%.
- Measure the current ripple and test the stability of the output current accurately to make sure the output current meet the requirements of the Kr lamp.

Chapter 2 Explanation of Model Number

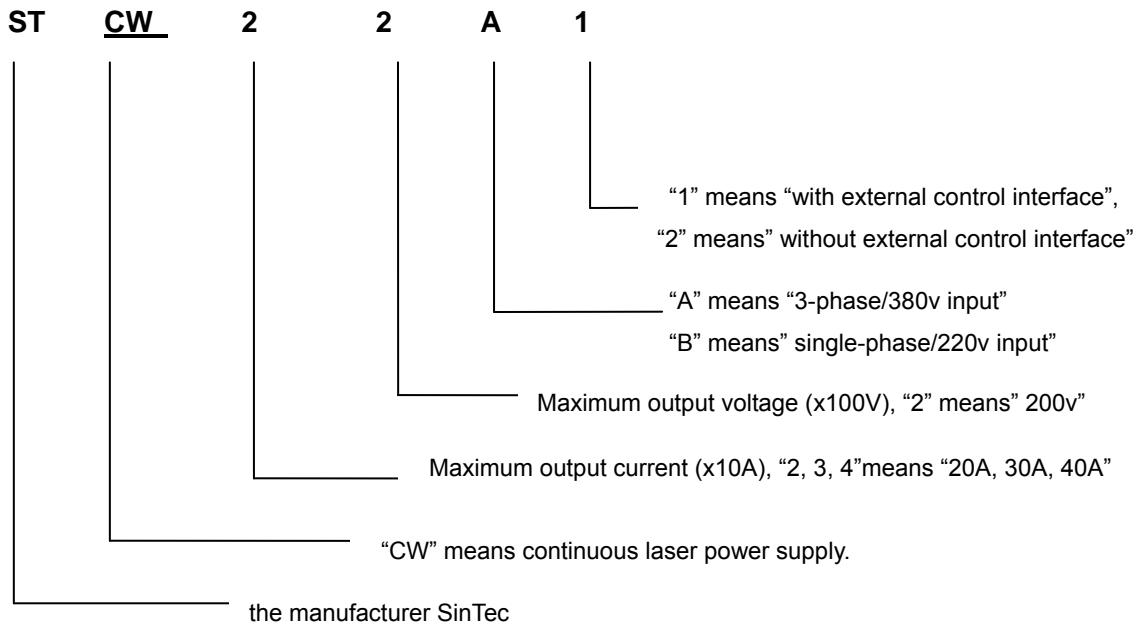

Chapter 3 Main Technical Specifications

Maximum output voltage: 500V (3 grades: 500V, 400V, 200V)

Maximum output current: 30A (4 grades: 20A, 25A, 30A, 40A)

Current ripple: $\leq 0.4\%$

Control accuracy: 0.4%

Simmer current: 7A

Switch frequency: 20KHZ

AC input power: 220VAC $\pm 15\%$ or 380VAC

Ambient temperature: 0 to 50 °C

Air humidity: $\leq 90\%$

Model	STCW22A	STCW32A	STCW24A	STCW22B	STCW32B
Max output current	25	30	20	20	30
Max output voltage	200V	200V	400V	200V	200V
Current ripple	$\leq 0.4\%$	$\leq 0.4\%$	$\leq 0.4\%$	$\leq 0.4\%$	$\leq 0.4\%$
Control accuracy	0.4%	0.4%	0.4%	0.4%	0.4%
Simmer current	7A	7A	7A	7A	7A
Switching frequency	20KHZ	20KHZ	20KHZ	20KHZ	20KHZ
Allowed input voltage tolerance	$\pm 15\%$	$\pm 15\%$	$\pm 15\%$	$\pm 15\%$	$\pm 15\%$
Environment temperature	0~50 °C	0~50 °C	0~50 °C	0~50 °C	0~50 °C
Environment humidity	$\leq 90\%$	$\leq 90\%$	$\leq 90\%$	$\leq 90\%$	$\leq 90\%$
Input electricity	380V, 6KVA	380V, 9KVA	380V, 11KVA	220V, 6KVA	220V, 9KVA

Dimension (mm)	500x481x135	500x481x135	500x481x135	500x481x180	500x481x180
Weight	23.5kg	23.5kg	25kg	23.5kg	23.5kg

Chapter 4 Installation

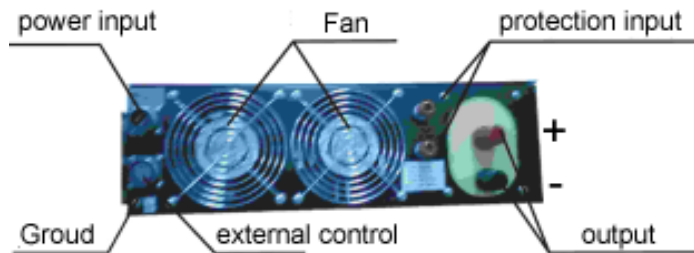

Fig1. Back panel (external control will be blocked if external control does not come)

4.1 AC Power Input

The power supply are connected to the main electricity via a standard P20K6Q circular connector. For 3-phase 380VAC input, PINs 1, 2 and 3 are respectively connected to live lines (no requirement on phase sequence) and PIN 4 is connected to neutral line as shown in Fig. 2. For 220VAC input, PINS 1 and 2 should be connected and then connected to live line. PINs 3 and 4 should be connected and then connected to neutral line as shown in Fig. 3. Default input is 3-phase.

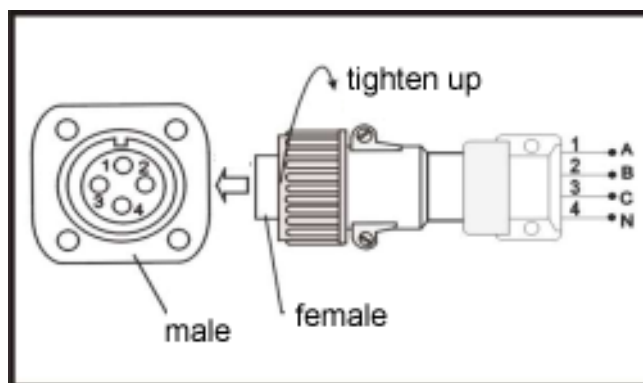

Fig. 2: Connection of 3-phase/380v AC source input

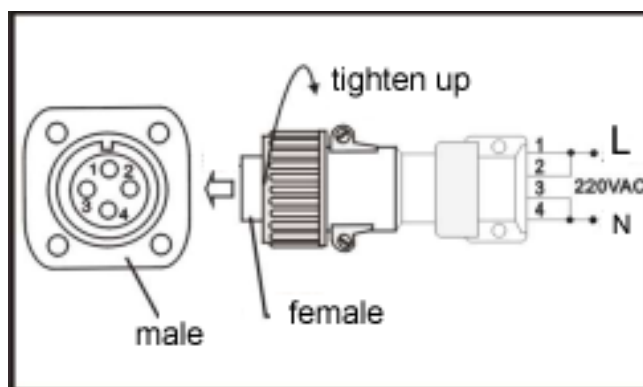

Fig. 3. Connection of single-phase/220v AC source input

WARNING: carefully check the numbers of PINs. In-correct connection may damage to the power supply.

4.2 Connection to the krypton lamp

The two binding posts at the back panel are connected to the krypton lamp. The red post links to anode “+” of the lamp, and the black post links to cathode “-”. Please remember that a voltage with about thirty thousands volts occurs at ignition and thus the insulation is very important. The distance between high voltage wires and any other conductor must be large than 30mm.

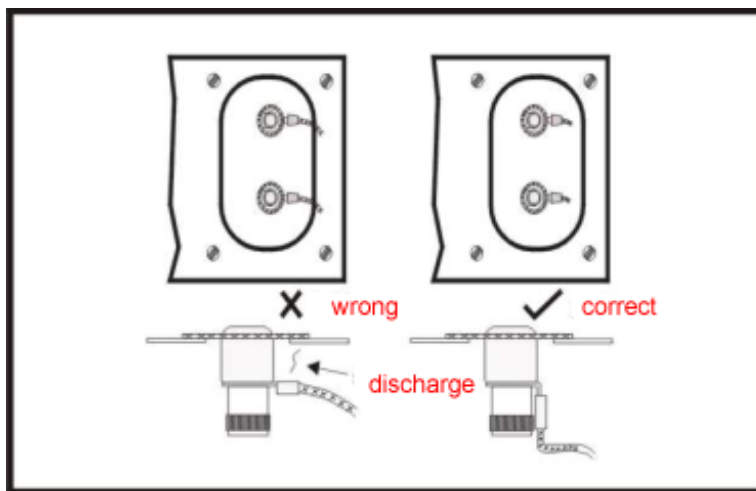
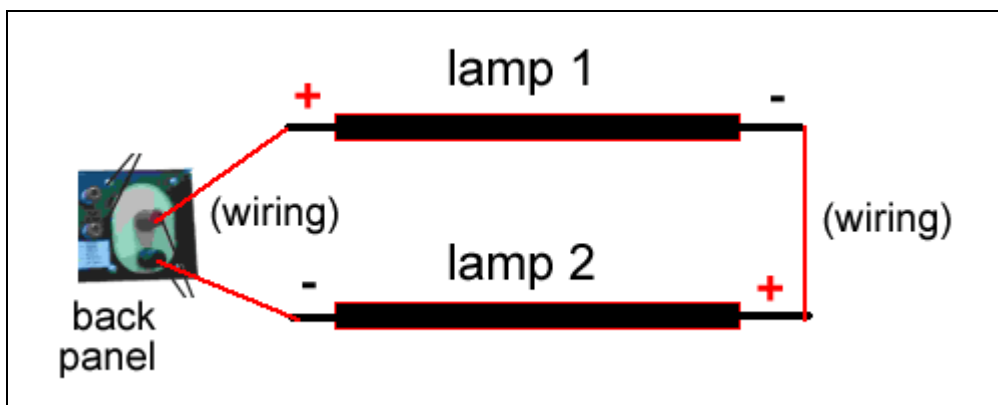

Fig. 4. Connection to the krypton lamp

If the driver drives 2pcs lamps, the 2pcs lamps are connected by wiring in series as shown in the following picture:



WARNING:

- 1 Wrong connection to the krypton lamp may damage to the lamp.
- 2 Tightly Screw the binding posts. Loose connection may decrease the successful ratio of ignition due to the larger contact resistance.
- 3 DO NOT startup the power supply before the lamp is right connected.
- 4 If the lamp can not be ignited three times, please check the insulation between the lamp and other conductors.

4.3 External control

The default configuration is without external control.

Connections to external interface with “sleep” function and without “sleep” function are shown Fig. 5 and Fig. 6 respectively. Notice that you must input a high level signal PIN 16 compared with contact of number 17 for operation. Otherwise the power supply would be in the “sleep” state at all times after ignition.

The default connection to external interface is given by Fig. 7, plug in the socket and tightly screw the knob before the use of the power supply. If the user does not choose the external control function when placing the order, the connection is done as shown in Fig. 7 in factory and the user do not need do the connection of the external control.

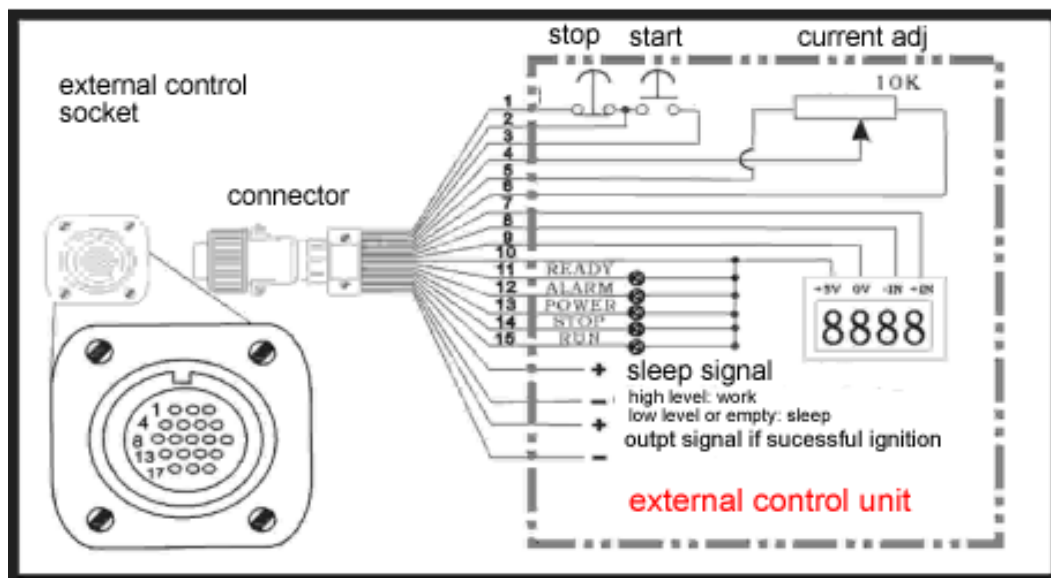

Fig. 5. Connection of the external interface (with “sleep” control)

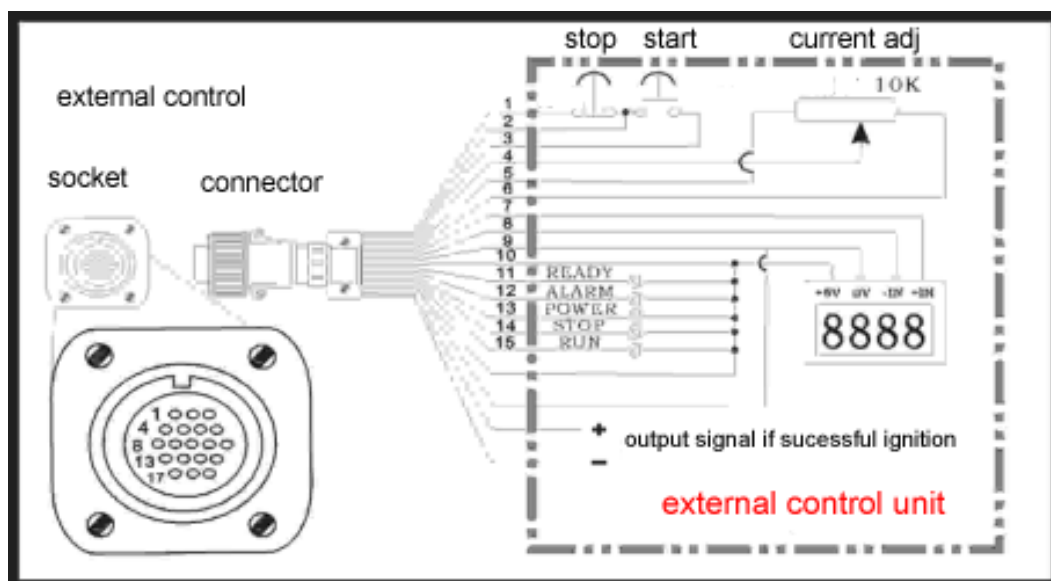

Fig. 6 Connection of the external interface (without “sleep” control)

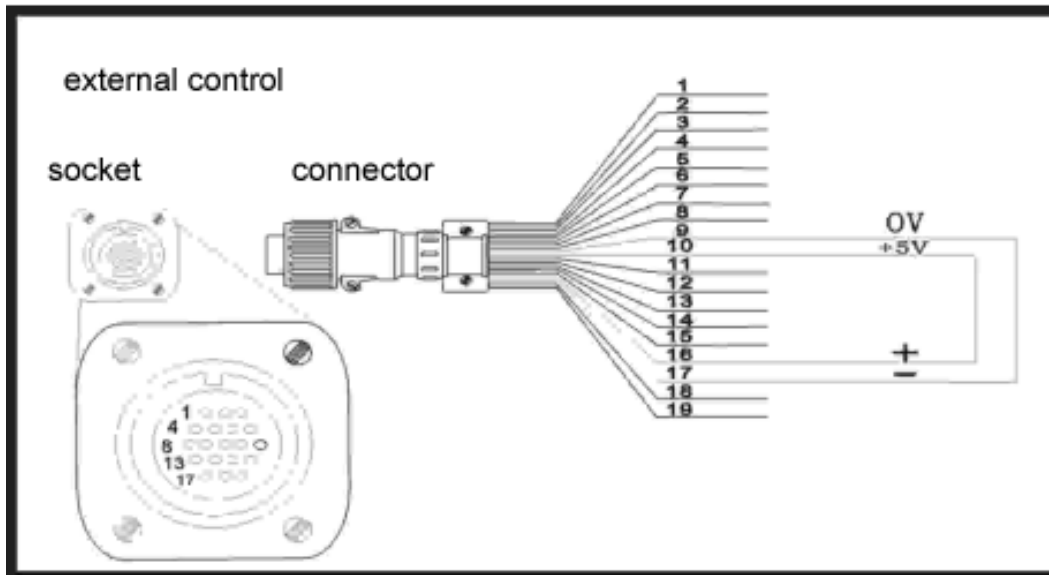

Fig. 7. Default connection of the external interface

4.4 Protection Input

The protection input, generally connected to the flow switch of a chiller, is intended to stop operation without proper cooling. The power supply can normally operate only after Protection Input is shorted. Thus please give it a protection connection from other parts such as chiller, or a relay.

4.5 Grounding

The housing of the power supply MUST be connected to ground and a terminal for connecting to the ground is at the back panel of the housing.

Chapter 5 Operation Instructions

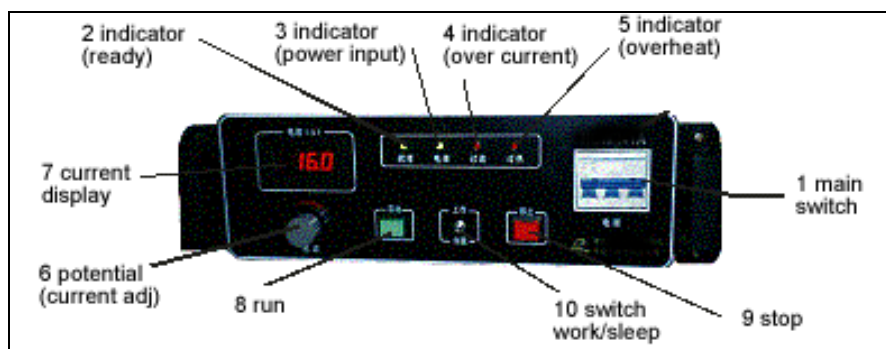

Fig. 8. Front panel (without external control interface)

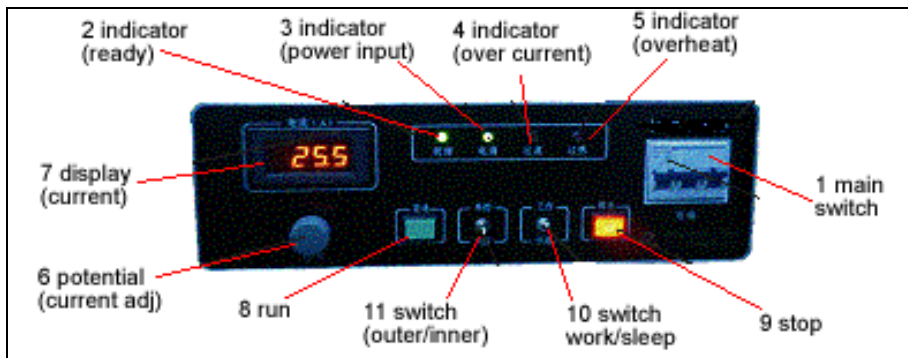

Fig. 9 Front panel (with external control interface)

5.2.1 Main switch

turns on/off main AC power to the system

5.2.2 “ready” LED

Indicates the power supply is ready to work. The “ready” LED will be in green lighting only three seconds after the device is switched on.

5.2.3 “Power” LED

Indicates the main power is switched on.

5.2.4 “overload” LED

“overload” LED comes on in red in the event of overcurrent.

5.2.5 “overheat” LED

Monitors the temperature of the power supply.

5.2.6 Current knob

Adjusts the output current.

5.2.7 Current display

Displays the value of operating current (when working) and preset value of current (when standing by).

5.2.8 “run” button

Press to start the power supply and the run light comes on in green at the same time.

5.2.9 “stop” button

Press this button to stop working and the red light comes on at the same time.

5.2.10 “sleep/work” switch

The power supply outputs simmer current (7A) of the lamp in “sleep” state and operating current in “work” state.

REMARKS:

1. Setting operating current by the rotary potentiometer, or working according to the parameters

set last time. Start the power supply in “sleep” state to avoid in-rush current and the output current is 7A at this time. Then switch the power supply to “work” state, the output current would automatically rise to the target current (pre-set current). The operation to stop working is similar to startup. Recommend stopping working in the “sleep” state.

2. In the “sleep” state, the current can NOT be adjusted by the potentiometer, but can preset the operating current.

5.2.11 outer/inner switch

Turn the outer/inner switch to “outer”, the power supply is controlled by the external signal through the external control interface. Turn the switch to “inner”, the device is controlled by the front panel.

5.3 Main protection functions

5.3.1 Undervoltage protection

The undervoltage circuit unit will be active and “ready” LED lights off in the event of the input voltage below 85% of the nominal voltage. At the time, power supply is automatically shut down and will NOT restart even pressing the “run” button. The device can restart only after the input voltage is in the normal range (within 15% variation of the nominal value) and press “run” key again.

The power supply can NOT restart automatically even the line voltage restore to nominal value after a while. When the “ready” LED comes on, the power supply can start by pressing the “run” button again,

5.3.2 Overcurrent protection

The “overcurrent” LED comes on in the event of the output current exceed the maximum output current and the power supply is automatically shut down. Check the IGBT module carefully. If it still works well, please replace the main control board.

ARNING: Only authorized person can carry out this work.

5.3.3 Overheating protection

The power supply will atomically shut down when the temperature of the heat sink exceeds 75 °C and “overheat” LED comes on.

Recommend to improve the convection of air for dissipation of the heat to avoid damage caused by overheat,

5.3.4 Protection Input

The two red binding posts at the back panel is connected to a protection. The power supply can start only when the two binding post of the protection input is short, or “run” key is invalid.

The power supply will shut down if the two binding post is open. You must press the “run” button to restart the device after the two binging posts is connected again.

Chapter 6 Attentions

- 8.1 Starting the power supply without any load is strictly prohibited. Otherwise the components may be damaged due to the high voltage occurred at the time of ignition.
- 8.2 Correctly connect the Kr lamp.
- 8.3 Tightly screw circular connector.
- 8.4 DO NOT short the protection input. Manual shorting the protection input may cause serious accident such as lamp blast since there is no any protection.
- 8.5 DO NOT open the cover of the power supply except trained person; DO NOT adjust any other parameters or circuits. Contact us if there are problems you can not deal with.
- 8.6 The power supply must be connected to the ground.

Chapter 7 Troubleshooting Guide

The user can deal with some usual malfunctions according to the list given below. Safety must be guaranteed when operating. Only the authorized person is allowed to adjust or replace any units of the products.

Malfunctions	Possible cause	Remedy
The panel doesn't work	<ul style="list-style-type: none"> ● Main switch is not switched on ● Failure to connect to the AC input 	<ul style="list-style-type: none"> ● Switch on the power supply ● Check the AC source
“run” key invalid	<ul style="list-style-type: none"> ● Binding posts of protection input ● Malfunction in protection input 	<ul style="list-style-type: none"> ● Check the binding posts of the protection input ● Check the protection input
The lamp can not be ignited	<ul style="list-style-type: none"> ● Connect wires from Kr lamp is not well contacted to the binging posts of high voltage. ● High voltage pulse level is too low. ● Dual-lamp is loaded on the power supply just for single lamp. ● Insulation between the electrodes of the Kr lamp and the pedestal is not good. ● The lamp is broken. ● Fuse F1 (0.5A) in igniting board (LX-GYDHB) dropped out. 	<ul style="list-style-type: none"> ● Connect the wires tightly ● Set to the next higher level. ● Change the load to single lamp. ● Check the insulation between the electrodes of the Kr lamp and the pedestal. ● Change the lamp. ● Change the fuse.
Potentiometer invalid	<ul style="list-style-type: none"> ● “sleep/work” switch is turned to “sleep” ● Potentiometer is defective. 	<ul style="list-style-type: none"> ● Turn the “sleep/work” switch to “work” ● Change the potentiometer ● Plug the external control interface in with the

		accessories provided
Power supply shut down automatically	<ul style="list-style-type: none">● Overheat● Malfunction in the system of heat dissipation	<ul style="list-style-type: none">● contact us● Check the fans and improve the air convection
Automatically Shut down and “ready” LED flash to off	Short-circuit capacity of the power network is too small; the equivalent internal impedance of the power network is too large.	Increase the short-circuit capacity of the power network or contact us. The malfunction caused by this cause occurs relatively more often in model STCWB which with single-phase AC voltage input.

Chapter 8 Accessories

8.1 Accessories



Fig. 10 Accessories (without external control interface)



Fig. 13 Accessories (with external control interface)

8.2 Dimension (unit: mm)

465mm in the picture is the size after the terminal block is connected, user should keep enough space for the terminal block, and then consider to improve the air convection on the left and right side.

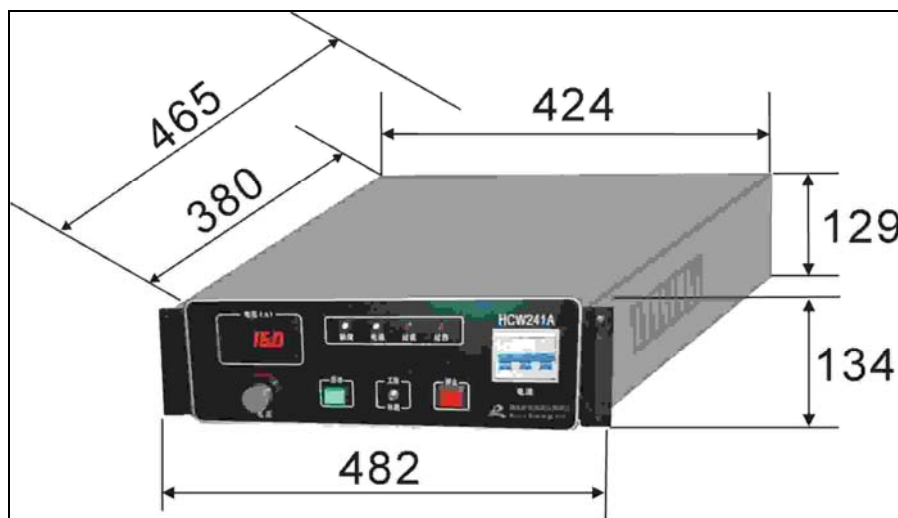

Fig. 14 Dimensions

Chapter 9 The Definition of External Control Interface

(externally controlled by voltage or computer)

The External Control Interface of the CW laser power supply is to be connected with a computer or outside controllers, used for starting/stopping power supply, monitoring working status of power supply, and adjusting the output current.

1. Definition of PINs of External Control Interface

The default connector is DB9. The PINs are shown by Fig. 1.

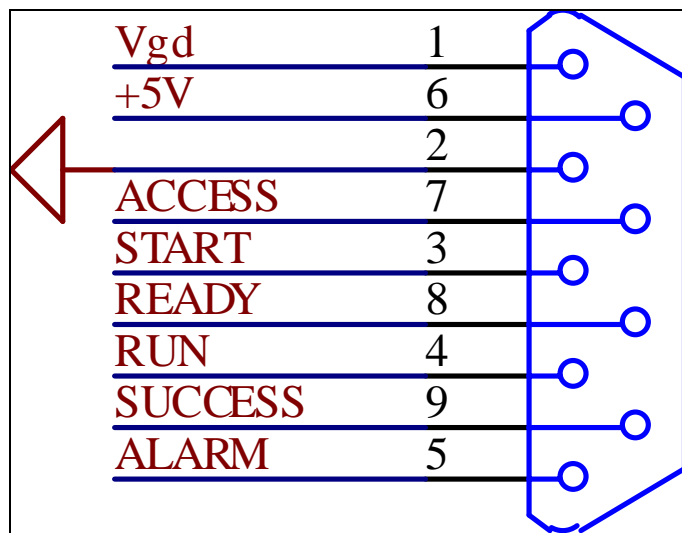

Fig. 15 PINs description og external control interface

2. Description of PINs in DB9

2.1 Setting current signal - Vgd (PIN 1, Input analog signal)

The setting current signal (Vgd) is used to adjust output current (Io). The available range of Vgd is 3.15V~9V, corresponding to output current of Iomin to Iomax (Iomin=7A, Iomax≤30A). The relation between Io and Vgd is shown as follows:

If $Vgd \leq 3.15V$, $Io \equiv Iomin$

If $Vgd \in (3.15V \sim 9V)$, $Io = \frac{Iomax - Iomin}{5.85} (Vgd - 3.15) + Iomin$

If $Vgd \geq 9V$, $Io \equiv Iomax$

REMARKS: We suggest the user to input $Vgd \leq 3.15V$ when starting the power supply to avoid in-rush current.

2.2 Ground signal – GND (PIN 2)

2.3 Start-up signal – START (PIN3, Input high level availability, TTL)

The power supply will start when the Start-up signal is at high level . If the Start-up signal is at low level, the power supply will stop.

2.4 Running signal – RUN (PIN 4, Output high level availability, TTL)

This signal is provided to external controller for checking the status of the power supply. PIN 4 outputs high level signal, when the power supply working is OK. But the 3 following conditions

need to be satisfied:

- a. READY signal is high level
- b. START signal is high level
- c. Water-cooling is OK.

2.5 Alarm signal – ALARM (PIN 5, Output high level availability, TTL)

If PIN 5 outputs high level signal, the power supply will automatically stop and that means that the working status of power supply is over current or over heat. At this time the START signal must be set to low level to avoid misoperation.

2.6 Outputs +5V (PIN 6)

2.7 External-control authorization signal – ACCESS (PIN7, Output high level availability, TTL)

If PIN 7 outputs high level signal, the external interface will control the power supply to start/stop, and adjust the operation current, then the connector DB9 turn to be available. If PIN 7 outputs low level signal, the power supply will be started/stopped and the output current will be adjusted only through the front panel (by the power supply itself).

2.8 Ready for working signal – READY (PIN8, Output high level availability, TTL)

If PIN 8 outputs high level signal, that indicates that the power supply is ready to start. If PIN8 outputs low level signal, that indicates that the power supply can't work. The reasons may be:

- i. Main control board losses electricity.
- ii. Input voltage is below 85% of the nominal voltage.
- iii. The soft-charging circuit faults
- iv. ALARM signal outputs high level.

2.9 Igniting lamp success signal – SUCCESS (PIN9, Output high level availability, TTL)

If PIN 9 outputs high level signal, that indicates that the lamp has been ignited. The output current can be adjusted by setting Vgd.

Company Profile

We, Sintec Optronics Pte Ltd, are a Singapore-based supplier & manufacturer of a wide range of photonics products (lasers & parts, optical components, and relevant accessories). We provide various high-quality low-price lasers, parts & optics for OEM and end users. The company is managed by experienced professionals with engineering & servicing backgrounds. Our customers range over 32 countries around the world.

1. Lasers & Machines

- 1.1 Sealed CW CO2 lasers
- 1.2 CW Nd:YAG laser systems
- 1.3 Diode-pumped YAG lasers
- 1.4 Diode pumped green lasers
- 1.5 Pulse Nd:YAG lasers
- 1.6 High-power diode lasers
- 1.7 Red diode lasers
- 1.8 Diode-pumped green lasers
- 1.9 Laser cutting machines
- 1.10 Laser marking machines
- 1.11 Laser welding machines
- 1.12 Laser engraving machines

2. Optical Components

- 2.1 Focusing lenses
- 2.2 Mirrors & output couplers
- 2.4 Beam expanders
- 2.5 Zoom beam expanders
- 2.6 Beam splitters
- 2.7 Scan mirrors
- 2.8 Scan lenses (f-theta lenses)

3. Accessories

- 3.1 Laser lamps (Kr and Xe lamps)
- 3.2 CW and pulse Nd:YAG laser power supply
- 3.3 Diode laser drivers
- 3.4 Laser chillers/heat exchangers
- 3.5 Laser crystals & optical crystals (YAG rods, KTP, BBO, ZnSe etc)
- 3.3 AO & EO Q-switches & drivers
- 3.4 Acousto-optic modulators (AOMs)
- 3.5 Laser power/energy meters
- 3.6 Laser safety goggles
- 3.7 Optical scanners/galvanometers
- 3.8 Motorized or manual adjustable XYZ stages & rotary stages
- 3.9 Vertical translation stages
- 3.10 Linear translation stages
- 3.11 Mirror mounts, holders, posts & holders
- 3.12 CNC control software
- 3.13 Laser marking heads and marking software
- 3.14 Laser pump chambers
- 3.15 Ceramic reflectors
- 3.16 Diffractive optical elements

We are a leading company in Singapore to provide quality laser systems & optical components and excellent services at attractive prices. We always try our best to make our products reliable, safe, easy to use, flexible and economical. We believe our continuing advances in technologies will make us the best choice to provide the solutions to make you remain competitive and be a leader in your own field.