

Diode Driver

Operation Manual



Sintec Optronics Pte Ltd

196 Pandan Loop #07-26

Pantech Industrial Complex Singapore 128384

Tel: +65 67781866 Fax: +65 67781781

E-mail: sales@SintceOptronics.com or sales@sintecoptronics.com.sg

URL: <http://www.SintecOptronics.com> or <http://www.SintecOptronics.com.sg>

Sintec Optronics Pte Ltd

We, Sintec Optronics Pte Ltd, are a Singapore-based supplier of a wide range of photonics products (lasers & parts, optical components, and relevant accessories). We provide various high-quality low-price lasers, parts & optics for OEM and end users. The company is managed by experienced professionals with engineering & servicing backgrounds. Our customers range over 32 countries around the world.

1. Lasers

- 1.1 Sealed CW CO2 lasers
- 1.2 CW Nd:YAG laser systems
- 1.3 Diode-pumped YAG lasers
- 1.4 Diode pumped green lasers
- 1.5 Pulse Nd:YAG lasers
- 1.6 High-power diode lasers
- 1.7 Red diode lasers
- 1.8 Diode-pumped green lasers
- 1.9 Fiber Lasers

2. Optical Components

- 2.1 Focusing lenses
- 2.2 Mirrors & output couplers
- 2.4 Beam expanders
- 2.5 Zoom beam expanders
- 2.6 Beam splitters
- 2.7 Scan mirrors
- 2.8 Scan lenses (f-theta lenses)

3. Accessories

- 3.1 Laser lamps (Kr and Xe lamps)
- 3.2 CW and pulse Nd:YAG laser power supply
- 3.3 Diode laser drivers
- 3.4 Laser chillers/heat exchangers
- 3.5 Laser crystals & optical crystals (YAG rods, KTP, BBO, ZnSe etc)
- 3.3 AO & EO Q-switches & drivers
- 3.4 AOMs
- 3.5 Laser power/energy meters
- 3.6 Laser safety goggles
- 3.7 Optical scanners/galvanometers
- 3.8 Motorized or manual adjustable XYZ stages & rotary stages
- 3.9 Vertical translation stages
- 3.10 Mirror mounts, holders, posts & holders
- 3.11 Optical tables
- 3.12 CNC control software
- 3.13 Laser marking heads and marking software
- 3.14 Laser pump chambers

We are a leading company in Singapore to provide quality laser systems & optical components and excellent services at attractive prices. We always try our best to make our products reliable, safe, easy to use, flexible and economical. We believe our continuing advances in technologies will make us the best choice to provide the solutions to make you remain competitive and be a leader in your own field.

Sintec Optronics Pte Ltd

196 Pandan Loop #07-26 Pantech Industrial Complex Singapore 128384

Tel: +65 67781866 Fax: +65 67781781

E-mail: sales@SintecOptronics.com or sales@SintecOptronics.com.sg

URL: <http://www.SintecOptronics.com> AND <http://www.SintecOptronics.com.sg>

Main Specifications:

- Dimension: 19", 2U box, 482×88x400mm
- Input electricity, 220VAC, 1200W (option: 110VAC, 1200W)
- Output: 18-36VDC, 1-28ADC adjustable
- Ripple voltage: <60mV
- Over current setting: 30.5ADC, over voltage setting: 36.5VDC (other setting available upon request.)
- External control of output current
- Alarm/protection: empty load or short circuit.

Front Panel

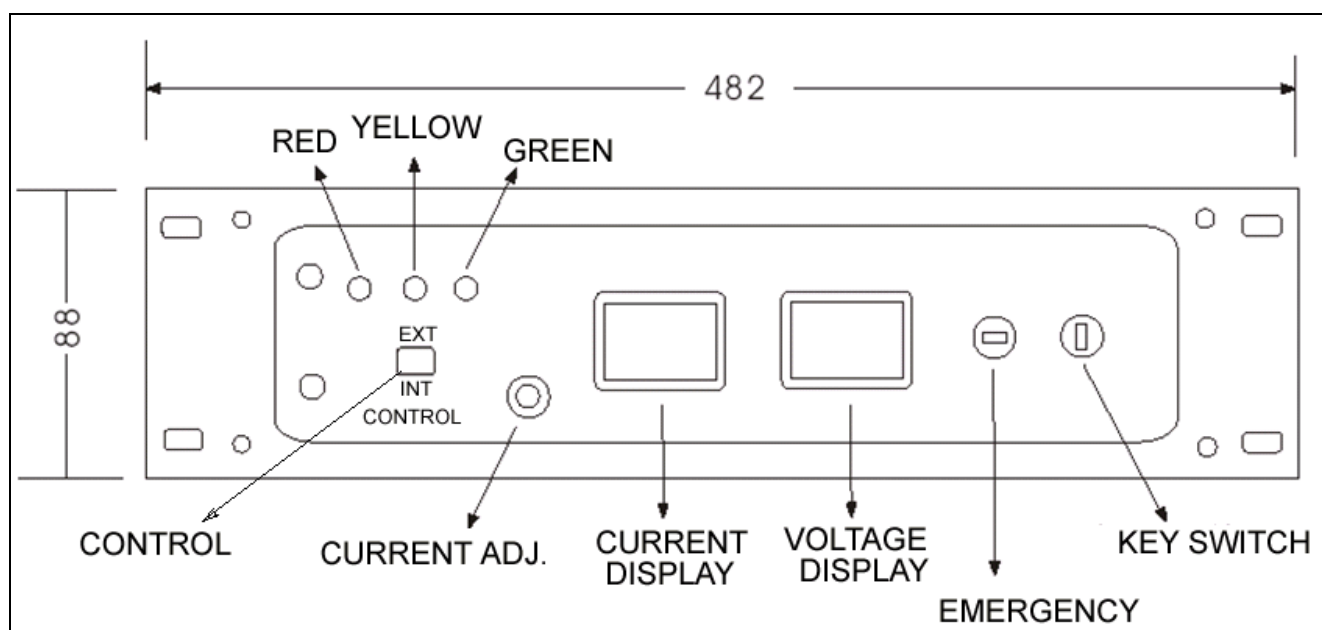

- Indicator YELLOW: preparation status. All are ready for operation.
- Indicator GREEN: normal operation status
- Indicator RED: protection status (stopped). Possible causes are PROTECTION activated, loading is open or shorted (that is that the diode laser is not well connected with the driver), over current, over voltage etc.
- CONTROL: the output current is adjusted by EXT (input voltage 0 to 10VDC) or by INT (potentiometer CURRENT ADJ on the front panel).
- CURRENT ADJ: adjust output current when the control is INT.
- CURRENT DISPLAY: display the operation current
- VOLTAGE DISPLAY: display the output voltage.
- EMERGENCY: press the button for emergent stop.
- KEY SWITCH: switch on/off the diode driver.

WARNING: once the indicator RED is light on, you should anti-clockwise adjust CURRENT ADJ to the end.

Rear Panel

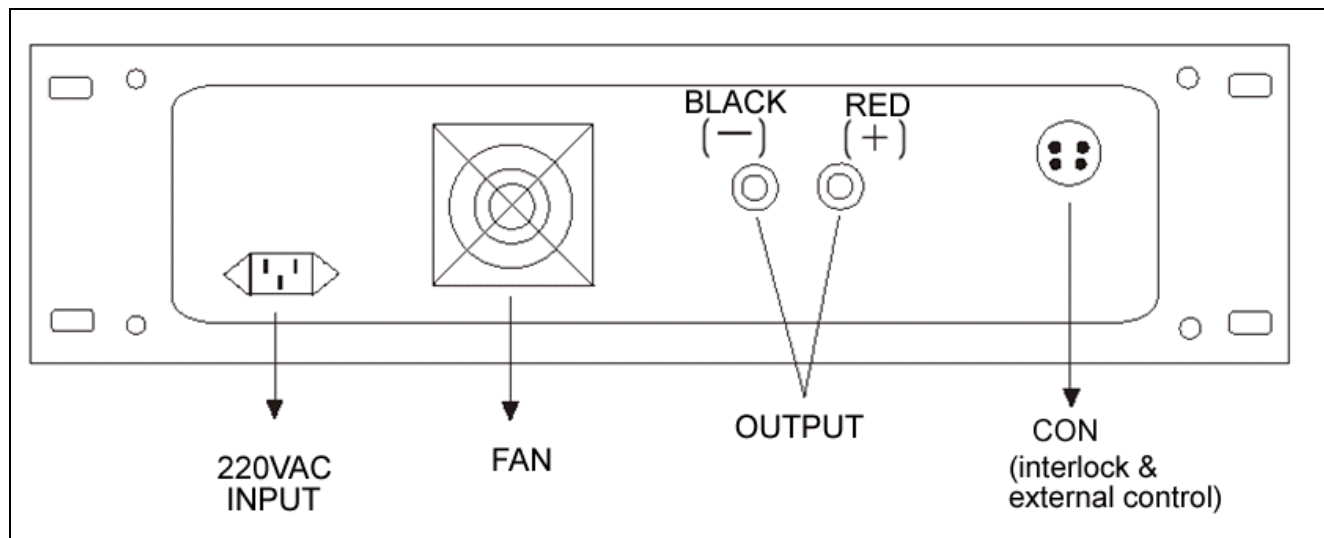

- CON:
 - (1) PIN 1 and PIN2 for interlock: when shorted, the driver can output; when open, the driver can not output (protected).
 - (2) PIN 3 and PIN4 for external control input. When the control is EXT (external), the output current is controlled and adjusted by the input voltage 0-10VDC from PIN3 (+) and PIN4 (-). The output current is 0 when the input voltage is 1A and the output current is maximum (here is 30A) when the input voltage is 10VDC.
- OUTPUT: connected to diode laser or other loads. **Please note the polarity.**
- 220VAC INPUT: electricity input.

Operation Procedures:

Before starting operation

1. Connect the diode laser with the driver (please note the polarity).
SUGGESTION: if there is a resistor such as 1ohm/50W, you may try the driver to drive the resistor first and then drive the diode since the diode is very expensive.
2. Connect the signal from the external machine/signal to PROTECTION (interlock). If you do not want PROTECTION from other equipment, just short PINS 1 & 2 of PROTECTION.
3. Connect 220VAC INPUT to the diode driver.
4. Select EXT or INT for CONTROL.
5. Anti-clockwise adjust CURRENT ADJ to the end.
Warning: if you do not anti-clockwise turn CURRENT ADJ (potentiometer) to the end, you can not power on the diode driver.

Start operation

1. Turn on KEY SWITCH.
2. Turn on START/EMERGENCY.
3. If you select INT control, clockwise adjust CURRENT ADJ to the current you want.
4. If you select EXT control, please input the control voltage to let output current be what you wanted. Please note that the initial voltage must be 0 and then increase your input voltage.

Close the driver

1. Anti-clockwise adjust CURRENT ADJ to the end.
2. Turn off START/EMERGENCY and KEY SWITCH.

